

商品ID	SKU编码	商品名称	69码	UPC码	产品型号	SPU
45255	BHR6992GL	Redmi Buds 4 Active	6941812712733	190997004928	M2232E1	SPU1012773

PANTONE COOL GRAY 11C

折页1：9折

折页2：1折

说明书：风琴折页，展开尺寸**180x900m** 折叠尺寸：90*90mm，80g金东太空梭

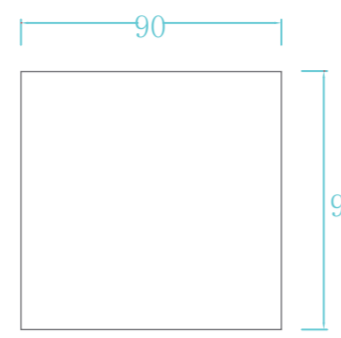

英 俄 法 西 印尼 阿拉伯
EN RU FR ES ID SA

Redmi全球版

POCO Technical 7.5pt. Specifications
POCO Technical. Note-Wireless Display

<p>Redmi Buds 4 Active User Manual Pisayocagho Hoxobaxobaxo Hoxayomaxo Redmi Buds 4 Active Manual d'Utilisation de Redmi Buds 4 Active Manual de usuario de Redmi Buds 4 Active Pamflet Pengantar Redmi Buds 4 Active Redmi Buds 4 Active คู่มือผู้ใช้</p>						<p>English Please read this user manual carefully before using the product. It contains important information about the product's features, functions, and safety. Keep this manual for future reference.</p> <p>Chinese 请仔细阅读本用户手册，以便正确使用本产品。手册中包含了有关产品功能、特性和安全的重要信息。请妥善保管，以备将来参考。</p> <p>Spanish Lea atentamente este manual de usuario antes de utilizar el producto. Contiene información importante sobre las características, funciones y seguridad del producto. Mantenga este manual a mano para futuras referencias.</p> <p>French Lisez attentivement ce manuel de l'utilisateur avant d'utiliser le produit. Il contient des informations importantes sur les caractéristiques, les fonctions et la sécurité du produit. Gardez ce manuel à portée de main pour référence ultérieure.</p> <p>German Bitte lesen Sie dieses Benutzerhandbuch sorgfältig vor dem Gebrauch des Produkts. Es enthält wichtige Informationen zu den Funktionen, den Eigenschaften und der Sicherheit des Produkts. Bewahren Sie dieses Handbuch für zukünftige Referenzen auf.</p> <p>Italian Leggere attentamente questo manuale dell'utente prima di utilizzare il prodotto. Contiene informazioni importanti sulle caratteristiche, le funzioni e la sicurezza del prodotto. Conservare questo manuale per future referenze.</p> <p>Japanese この取扱説明書をよく読んでから製品を使用してください。製品の機能、特徴、および安全に関する重要な情報が含まれています。この取扱説明書を将来の参照のために大切に保管してください。</p> <p>Korean 이 사용 설명서를 신중히 읽고 제품을 사용하기 전에 숙독하십시오. 이 설명서에는 제품의 기능, 특성, 및 안전에 대한 중요한 정보가 포함되어 있습니다. 이 설명서를 향후 참조를 위해 잘 보관하십시오.</p> <p>Russian Внимательно прочтите это руководство пользователя перед использованием продукта. Оно содержит важную информацию о функциях, особенностях и безопасности продукта. Сохраните это руководство для дальнейшего использования.</p> <p>Arabic يرجى قراءة هذا الدليل للمستخدم بعناية قبل استخدام المنتج. يحتوي على معلومات مهمة حول ميزات المنتج وخصائصه وأمانه. احتفظ بهذا الدليل كمرجع مستقبلي.</p>	<p>Indonesian Silahkan membaca buku petunjuk ini dengan seksama sebelum menggunakan produk. Buku petunjuk ini berisi informasi penting mengenai fitur, fungsi, dan keamanan produk. Simpan buku petunjuk ini sebagai referensi di masa depan.</p> <p>Malay Silahkan membaca buku petunjuk ini dengan seksama sebelum menggunakan produk. Buku petunjuk ini berisi informasi penting mengenai fitur, fungsi, dan keamanan produk. Simpan buku petunjuk ini sebagai referensi di masa depan.</p>	<p>Portuguese Leia este manual do usuário com atenção antes de usar o produto. Ele contém informações importantes sobre as características, funções e segurança do produto. Mantenha este manual para futuras referências.</p> <p>Vietnamese Hãy đọc kỹ hướng dẫn sử dụng này trước khi sử dụng sản phẩm. Tài liệu này cung cấp thông tin quan trọng về các tính năng, đặc điểm và an toàn của sản phẩm. Hãy giữ gìn tài liệu này để tham khảo sau này.</p>	<p>Connecting with App 1. Scan the QR code to download and install Xiaomi Wear to enable more features. 2. Follow the instructions on the app to connect the earbuds.</p> <p>Note: During the connection process, please make sure that the smartphone's Bluetooth is turned on and that the earbuds are in the charging case. Open the lid and ensure that your smartphone is near the box.</p>
<p>Specifications Name: Wireless Earbuds Model: M2232E1 Bluetooth: BT 5.3 Charging Case: 3.7V 300mAh Earbuds: 3.7V 50mAh Weight: 4.5g (per ear) Waterproof: IP54 (earbuds only)</p> <p>Important Safety Information • Do not use the product with damaged earbuds. There may be a risk of fire or explosion if used with damaged earbuds. • Do not use the product with damaged charging case. There may be a risk of fire or explosion if used with damaged charging case. • Do not use the product with damaged cables. There may be a risk of fire or explosion if used with damaged cables. • Do not use the product with damaged earbuds. There may be a risk of fire or explosion if used with damaged earbuds. • Do not use the product with damaged charging case. There may be a risk of fire or explosion if used with damaged charging case. • Do not use the product with damaged cables. There may be a risk of fire or explosion if used with damaged cables.</p>	<p>WARRENING NOTICE As a Bluetooth wireless earbuds, it may be used in a variety of environments. However, it is not recommended to use it in environments where there are strong electromagnetic fields, such as hospitals, airports, and military bases. It is also not recommended to use it in environments where there are high temperatures, such as saunas and hot tubs. It is also not recommended to use it in environments where there are high altitudes, such as mountains and high-altitude areas. It is also not recommended to use it in environments where there are high latitudes, such as the Arctic and Antarctic regions. It is also not recommended to use it in environments where there are high pressures, such as underwater and in high-pressure areas. It is also not recommended to use it in environments where there are high vibrations, such as in heavy machinery and in high-vibration areas. It is also not recommended to use it in environments where there are high speeds, such as in high-speed trains and in high-speed areas. It is also not recommended to use it in environments where there are high frequencies, such as in high-frequency areas and in high-frequency areas.</p>	<p>Important Safety Information • Do not use the product with damaged earbuds. There may be a risk of fire or explosion if used with damaged earbuds. • Do not use the product with damaged charging case. There may be a risk of fire or explosion if used with damaged charging case. • Do not use the product with damaged cables. There may be a risk of fire or explosion if used with damaged cables. • Do not use the product with damaged earbuds. There may be a risk of fire or explosion if used with damaged earbuds. • Do not use the product with damaged charging case. There may be a risk of fire or explosion if used with damaged charging case. • Do not use the product with damaged cables. There may be a risk of fire or explosion if used with damaged cables.</p>	<p>Important Safety Information • Do not use the product with damaged earbuds. There may be a risk of fire or explosion if used with damaged earbuds. • Do not use the product with damaged charging case. There may be a risk of fire or explosion if used with damaged charging case. • Do not use the product with damaged cables. There may be a risk of fire or explosion if used with damaged cables. • Do not use the product with damaged earbuds. There may be a risk of fire or explosion if used with damaged earbuds. • Do not use the product with damaged charging case. There may be a risk of fire or explosion if used with damaged charging case. • Do not use the product with damaged cables. There may be a risk of fire or explosion if used with damaged cables.</p>	<p>Important Safety Information • Do not use the product with damaged earbuds. There may be a risk of fire or explosion if used with damaged earbuds. • Do not use the product with damaged charging case. There may be a risk of fire or explosion if used with damaged charging case. • Do not use the product with damaged cables. There may be a risk of fire or explosion if used with damaged cables. • Do not use the product with damaged earbuds. There may be a risk of fire or explosion if used with damaged earbuds. • Do not use the product with damaged charging case. There may be a risk of fire or explosion if used with damaged charging case. • Do not use the product with damaged cables. There may be a risk of fire or explosion if used with damaged cables.</p>	<p>Important Safety Information • Do not use the product with damaged earbuds. There may be a risk of fire or explosion if used with damaged earbuds. • Do not use the product with damaged charging case. There may be a risk of fire or explosion if used with damaged charging case. • Do not use the product with damaged cables. There may be a risk of fire or explosion if used with damaged cables. • Do not use the product with damaged earbuds. There may be a risk of fire or explosion if used with damaged earbuds. • Do not use the product with damaged charging case. There may be a risk of fire or explosion if used with damaged charging case. • Do not use the product with damaged cables. There may be a risk of fire or explosion if used with damaged cables.</p>	<p>Technical Characteristics Name: M2232E1 Bluetooth: BT 5.3 Charging Case: 3.7V 300mAh Earbuds: 3.7V 50mAh Weight: 4.5g (per ear) Waterproof: IP54 (earbuds only)</p>	<p>Technical Characteristics Name: M2232E1 Bluetooth: BT 5.3 Charging Case: 3.7V 300mAh Earbuds: 3.7V 50mAh Weight: 4.5g (per ear) Waterproof: IP54 (earbuds only)</p>	<p>Technical Characteristics Name: M2232E1 Bluetooth: BT 5.3 Charging Case: 3.7V 300mAh Earbuds: 3.7V 50mAh Weight: 4.5g (per ear) Waterproof: IP54 (earbuds only)</p>	<p>Technical Characteristics Name: M2232E1 Bluetooth: BT 5.3 Charging Case: 3.7V 300mAh Earbuds: 3.7V 50mAh Weight: 4.5g (per ear) Waterproof: IP54 (earbuds only)</p>

<p>Connexion avec l'application 1. Scannez le code QR pour télécharger et installer l'application Xiaomi Wear. 2. Suivez les instructions de l'application pour connecter les écouteurs.</p> <p>Note: During the connection process, please make sure that the smartphone's Bluetooth is turned on and that the earbuds are in the charging case. Open the lid and ensure that your smartphone is near the box.</p>	<p>Specifications Name: Wireless Earbuds Model: M2232E1 Bluetooth: BT 5.3 Charging Case: 3.7V 300mAh Earbuds: 3.7V 50mAh Weight: 4.5g (per ear) Waterproof: IP54 (earbuds only)</p>	<p>Important Safety Information • Do not use the product with damaged earbuds. There may be a risk of fire or explosion if used with damaged earbuds. • Do not use the product with damaged charging case. There may be a risk of fire or explosion if used with damaged charging case. • Do not use the product with damaged cables. There may be a risk of fire or explosion if used with damaged cables. • Do not use the product with damaged earbuds. There may be a risk of fire or explosion if used with damaged earbuds. • Do not use the product with damaged charging case. There may be a risk of fire or explosion if used with damaged charging case. • Do not use the product with damaged cables. There may be a risk of fire or explosion if used with damaged cables.</p>	<p>Important Safety Information • Do not use the product with damaged earbuds. There may be a risk of fire or explosion if used with damaged earbuds. • Do not use the product with damaged charging case. There may be a risk of fire or explosion if used with damaged charging case. • Do not use the product with damaged cables. There may be a risk of fire or explosion if used with damaged cables. • Do not use the product with damaged earbuds. There may be a risk of fire or explosion if used with damaged earbuds. • Do not use the product with damaged charging case. There may be a risk of fire or explosion if used with damaged charging case. • Do not use the product with damaged cables. There may be a risk of fire or explosion if used with damaged cables.</p>	<p>Important Safety Information • Do not use the product with damaged earbuds. There may be a risk of fire or explosion if used with damaged earbuds. • Do not use the product with damaged charging case. There may be a risk of fire or explosion if used with damaged charging case. • Do not use the product with damaged cables. There may be a risk of fire or explosion if used with damaged cables. • Do not use the product with damaged earbuds. There may be a risk of fire or explosion if used with damaged earbuds. • Do not use the product with damaged charging case. There may be a risk of fire or explosion if used with damaged charging case. • Do not use the product with damaged cables. There may be a risk of fire or explosion if used with damaged cables.</p>	<p>Important Safety Information • Do not use the product with damaged earbuds. There may be a risk of fire or explosion if used with damaged earbuds. • Do not use the product with damaged charging case. There may be a risk of fire or explosion if used with damaged charging case. • Do not use the product with damaged cables. There may be a risk of fire or explosion if used with damaged cables. • Do not use the product with damaged earbuds. There may be a risk of fire or explosion if used with damaged earbuds. • Do not use the product with damaged charging case. There may be a risk of fire or explosion if used with damaged charging case. • Do not use the product with damaged cables. There may be a risk of fire or explosion if used with damaged cables.</p>	<p>Technical Characteristics Name: M2232E1 Bluetooth: BT 5.3 Charging Case: 3.7V 300mAh Earbuds: 3.7V 50mAh Weight: 4.5g (per ear) Waterproof: IP54 (earbuds only)</p>	<p>Technical Characteristics Name: M2232E1 Bluetooth: BT 5.3 Charging Case: 3.7V 300mAh Earbuds: 3.7V 50mAh Weight: 4.5g (per ear) Waterproof: IP54 (earbuds only)</p>	<p>Technical Characteristics Name: M2232E1 Bluetooth: BT 5.3 Charging Case: 3.7V 300mAh Earbuds: 3.7V 50mAh Weight: 4.5g (per ear) Waterproof: IP54 (earbuds only)</p>	<p>Technical Characteristics Name: M2232E1 Bluetooth: BT 5.3 Charging Case: 3.7V 300mAh Earbuds: 3.7V 50mAh Weight: 4.5g (per ear) Waterproof: IP54 (earbuds only)</p>
<p>Terhubung dengan Aplikasi 1. Pemindai kode QR untuk mengunduh dan menginstal aplikasi Xiaomi Wear. 2. Ikuti petunjuk aplikasi untuk menghubungkan earbuds.</p> <p>Note: During the connection process, please make sure that the smartphone's Bluetooth is turned on and that the earbuds are in the charging case. Open the lid and ensure that your smartphone is near the box.</p>	<p>Specifications Name: Wireless Earbuds Model: M2232E1 Bluetooth: BT 5.3 Charging Case: 3.7V 300mAh Earbuds: 3.7V 50mAh Weight: 4.5g (per ear) Waterproof: IP54 (earbuds only)</p>	<p>Important Safety Information • Do not use the product with damaged earbuds. There may be a risk of fire or explosion if used with damaged earbuds. • Do not use the product with damaged charging case. There may be a risk of fire or explosion if used with damaged charging case. • Do not use the product with damaged cables. There may be a risk of fire or explosion if used with damaged cables. • Do not use the product with damaged earbuds. There may be a risk of fire or explosion if used with damaged earbuds. • Do not use the product with damaged charging case. There may be a risk of fire or explosion if used with damaged charging case. • Do not use the product with damaged cables. There may be a risk of fire or explosion if used with damaged cables.</p>	<p>Important Safety Information • Do not use the product with damaged earbuds. There may be a risk of fire or explosion if used with damaged earbuds. • Do not use the product with damaged charging case. There may be a risk of fire or explosion if used with damaged charging case. • Do not use the product with damaged cables. There may be a risk of fire or explosion if used with damaged cables. • Do not use the product with damaged earbuds. There may be a risk of fire or explosion if used with damaged earbuds. • Do not use the product with damaged charging case. There may be a risk of fire or explosion if used with damaged charging case. • Do not use the product with damaged cables. There may be a risk of fire or explosion if used with damaged cables.</p>	<p>Important Safety Information • Do not use the product with damaged earbuds. There may be a risk of fire or explosion if used with damaged earbuds. • Do not use the product with damaged charging case. There may be a risk of fire or explosion if used with damaged charging case. • Do not use the product with damaged cables. There may be a risk of fire or explosion if used with damaged cables. • Do not use the product with damaged earbuds. There may be a risk of fire or explosion if used with damaged earbuds. • Do not use the product with damaged charging case. There may be a risk of fire or explosion if used with damaged charging case. • Do not use the product with damaged cables. There may be a risk of fire or explosion if used with damaged cables.</p>	<p>Important Safety Information • Do not use the product with damaged earbuds. There may be a risk of fire or explosion if used with damaged earbuds. • Do not use the product with damaged charging case. There may be a risk of fire or explosion if used with damaged charging case. • Do not use the product with damaged cables. There may be a risk of fire or explosion if used with damaged cables. • Do not use the product with damaged earbuds. There may be a risk of fire or explosion if used with damaged earbuds. • Do not use the product with damaged charging case. There may be a risk of fire or explosion if used with damaged charging case. • Do not use the product with damaged cables. There may be a risk of fire or explosion if used with damaged cables.</p>	<p>Technical Characteristics Name: M2232E1 Bluetooth: BT 5.3 Charging Case: 3.7V 300mAh Earbuds: 3.7V 50mAh Weight: 4.5g (per ear) Waterproof: IP54 (earbuds only)</p>	<p>Technical Characteristics Name: M2232E1 Bluetooth: BT 5.3 Charging Case: 3.7V 300mAh Earbuds: 3.7V 50mAh Weight: 4.5g (per ear) Waterproof: IP54 (earbuds only)</p>	<p>Technical Characteristics Name: M2232E1 Bluetooth: BT 5.3 Charging Case: 3.7V 300mAh Earbuds: 3.7V 50mAh Weight: 4.5g (per ear) Waterproof: IP54 (earbuds only)</p>	<p>Technical Characteristics Name: M2232E1 Bluetooth: BT 5.3 Charging Case: 3.7V 300mAh Earbuds: 3.7V 50mAh Weight: 4.5g (per ear) Waterproof: IP54 (earbuds only)</p>

印红色

文档密级：机密

表单编号：RE-PKG-002 版本：V5.0

图纸提供单位

万魔声学股份有限公司

项目名称

Redmi Buds 4 Active

图号（物料编码+版本号）

0301000946+ V1.0

设计时间

2023.03.28

设计师

Jimmy JIA

审核

ating Lian

材质工艺要求

材质要求：

环保要求：图中材料须符合TiinLab环境质量管理规范及TPCH & 无卤 & ROHS2.0 & REACH & POPs & TSCA

制作工序：印刷+哑膜/水性消光油+模切+贴胶带

工艺要求：色相正确、印迹牢固、套印准确、各色套印、不露杂色、套印误差≤ 0.1mm、模切走位± 0.5mm

(示例，具体以产品要求为准)

颜色及专色：

纹理要求

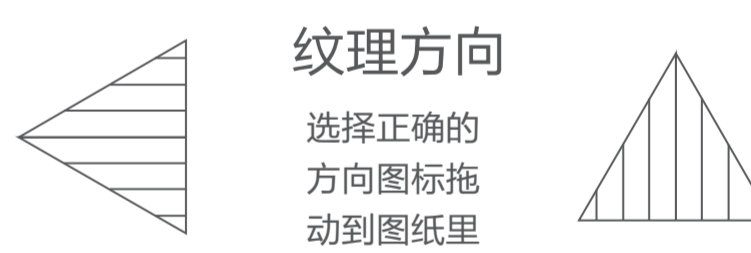

如有其它特殊要求，请写明

比例 1:1 单位 mm