

USER MANUAL

Smart True HEPA Air Purifier

Model: Core 200S Series

EN • DE • FR • ES • IT

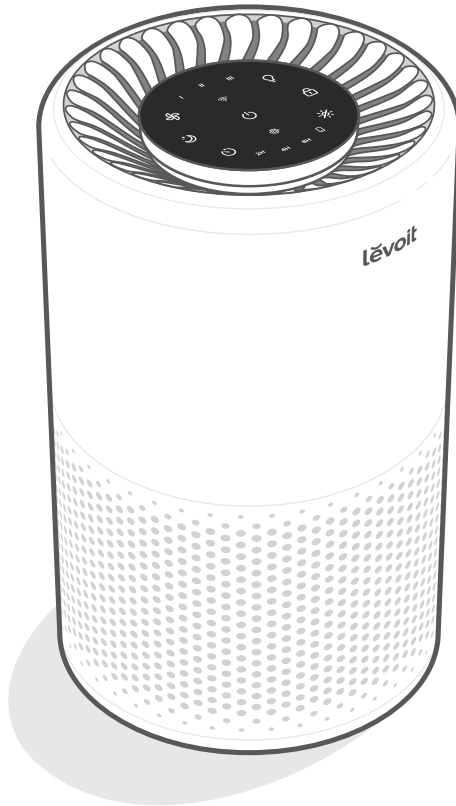

Questions or Concerns?

support.eu@levoit.com

Table of Contents

Package Contents	4
Specifications	4
Safety Information	5
Getting to Know Your Smart Air Purifier	6
Controls	7
Getting Started	8
VeSync App Setup	9
Using Your Smart Air Purifier	9
VeSync App Functions	11
About the Filter	12
Care & Maintenance	14
Troubleshooting	16
VeSync App Troubleshooting	18
About Energy-Related Products	19
Warranty Information	19
Customer Support	20

Inhaltsverzeichnis

Lieferumfang	21
Technische Daten	21
Sicherheitshinweise	22
Ihr Smart Luftreiniger	24
Bedienungstasten	25
Erste Schritte	26
Einrichten der VeSync-App	27
Der Gebrauch Ihres Smart Luftreinigers	27
VeSync App Funktionen	29
Informationen zum Filter	30
Pflege und Wartung	32
Problemlösung	35
Behebung von Problemen mit der VeSync-App	37
Informationen zu energieverbrauchsrelevanten Produkten	38
Informationen zur Garantie	39
Kundendienst	39

Índice

Contenido de la caja	40
Especificaciones	40
Información de seguridad	41
Componentes del purificador de aire inteligente	43
Controles	44
Primeros pasos	45
Configuración de la aplicación VeSync	46
Usar el purificador de aire inteligente	46
Funciones de la aplicación VeSync	48
El filtro	49
Cuidado y mantenimiento	51
Solución de problemas	54
Solución de problemas de la aplicación VeSync	56
Acerca de productos relacionados con la energía	57
Información sobre la garantía	58
Atención al Cliente	58

Table des matières

Contenu de l'emballage	59
Caractéristiques techniques	59
Consignes de sécurité	60
Découverte de votre purificateur d'air intelligent	62
Commandes	63
Prise en main	64
Configuration de l'application VeSync	65
Utilisation de votre purificateur d'air intelligent	66
Fonctions de l'application VeSync	68
À propos du filtre	69
Entretien et maintenance	71
Dépannage	74

Table des matières (suite)

Dépannage de l'application VeSync	74
Concernant les produits liés à l'énergie	77
Informations relatives à la garantie	78
Service client	78

Indice

Contenuto della confezione	79
Specifiche	79
Informazioni di sicurezza	80
Componenti del purificatore d'aria intelligente	81
Comandi	82
Avvio	84
Configurazione dell'app VeSync	84
Uso del purificatore d'aria intelligente	84
Funzioni dell'app VeSync	86
Il filtro	87
Cura e manutenzione	89
Risoluzione dei problemi	91
Risoluzione dei problemi dell'app VeSync	93
Prodotti che utilizzano energia	94
Informazioni sulla garanzia	95
Assistenza Clienti	95

Package Contents

- 1 x Smart Air Purifier
- 1 x 3-Stage Filter (Pre-Installed)
- 1 x User Manual
- 1 x Quick Start Guide

Specifications

Power Supply	AC 220–240V, 50Hz
Rated Power	26W
Ideal Room Size	35 m ² / 376 ft ² Note: <ul style="list-style-type: none"> • Effective for larger rooms, but purification will take longer. • Ideal Room Size is based on 2 air changes per hour (ACH).
CADR	170 m ³ /h
Operating Conditions	Temperature: -10°–40°C / 14°–104°F Humidity: < 85% RH
Noise Level	24–45dB
Air Purifier Dimensions	20.5 x 20.5 x 32 cm / 8.1 x 8.1 x 12.6 in
Air Purifier Weight	3 kg / 6.6 lb
Wi-Fi® Frequency Range	2412–2472MHz E.I.R.P.: 18.52dBm
Bluetooth® Frequency Range	2402–2480MHz E.I.R.P.: 9.84dBm

Note: To access additional smart functions, download the free VeSync app (see page 9).

READ AND SAVE THESE INSTRUCTIONS

SAFETY INFORMATION

To reduce the risk of fire, electric shock, or other injury, follow all instructions and safety guidelines.

General Safety

- **Only** use your air purifier as described in this manual.
- **Do not** use without removing the plastic wrap from the filter. The air purifier will not filter air, and may overheat, causing a fire hazard.
- **Do not** use the air purifier outdoors.
- Keep the air purifier away from water, and wet or damp areas. **Never** place in water or liquid.
- **Do not** use in excessively humid areas.
- Keep the air purifier away from heat sources.
- **Do not** use where combustible gases, vapours, metallic dust, aerosol (spray) products, or fumes from industrial oil are present.
- Keep 1.5 m / 5 ft away from where oxygen is being administered.
- Supervise children when they are near the air purifier.
- **Do not** place anything into any opening on the air purifier.
- **Do not** sit or place heavy objects on the air purifier.
- Keep the inside of the air purifier dry. To prevent moisture buildup, avoid placing in rooms with major temperature changes or underneath air conditioners.
- **Always** unplug the air purifier before servicing (such as changing the filter).
- **Do not** use the air purifier if it is damaged or not working correctly, or if the cord or plug is damaged. **Do not** try to repair it yourself. Contact **Customer Support** (see page 20).

- **WARNING:** To reduce the risk of fire or electric shock, **do not** use this air purifier with any solid-state speed controls (such as a dimmer switch).
- Not for commercial use. Household use **only**.

Power & Cord

- Keep the air purifier near the outlet it is plugged into.
- **Never** place the cord near any heat source.
- **Do not** cover the cord with a rug, carpet, or other covering. **Do not** place the cord under furniture or appliances.
- Keep the cord out of areas where people walk often. Place the cord where it will not be tripped over.

Electromagnetic Fields (EMF)

Your Levoit air purifier complies with all standards regarding electromagnetic fields (EMF). If handled properly and according to the instructions in this user manual, the appliance is safe to use based on scientific evidence available today.

GETTING TO KNOW YOUR SMART AIR PURIFIER

- | | | |
|-------------------------|---------------------------|---------------------|
| A. Fan Speed Indicators | H. Night Light Button | O. Power Cord |
| B. Fan Speed Button | I. Display Lock Button | P. Filter Cover |
| C. On/Off Button | J. Check Filter Indicator | Q. True HEPA Filter |
| D. Sleep Mode Button | K. Display Off Button | |
| E. Timer Button | L. Air Outlet | |
| F. Timer Indicators | M. Housing | |
| G. Wi-Fi Indicator | N. Air Inlet | |

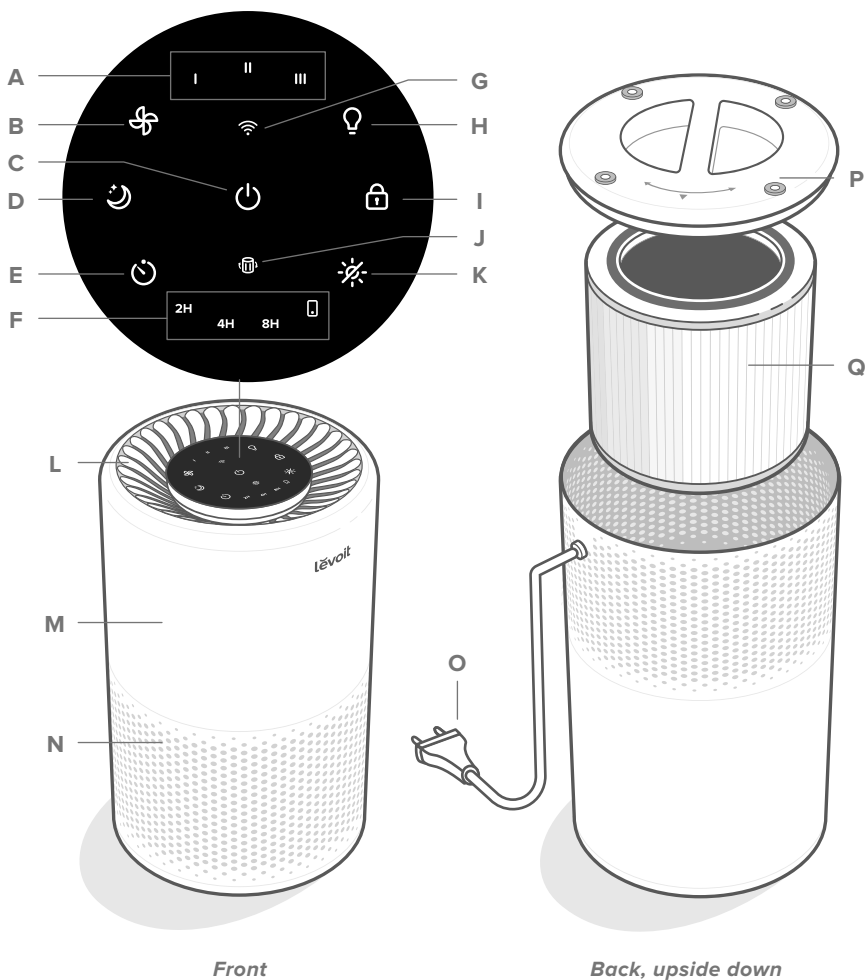

CONTROLS



On/Off Button

- Turns the air purifier on/off.
- Press and hold to configure the air purifier. See the VeSync in-app instructions for more information.



Night Light Button

- Turns the night light on/off (see page 10).



Wi-Fi Indicator

- Turns on, off, or blinks to indicate configuration status. See the VeSync in-app instructions for more information.



Display Off Button

- Turns the display off (not including the night light).
- Tap any button (except ) to turn the display back on.



Fan Speed Button

- Cycles through fan speeds: I (low), II (medium), and III (high).
- Tapping the Fan Speed Button while the air purifier is in Sleep Mode will exit Sleep Mode.



Display Lock Button

- Prevents current settings from being changed (see page 10).
- Blinks when any other button is tapped to indicate that Display Lock is on.



Sleep Mode Button

- Turns Sleep Mode on (see page 10).
- Press and hold for 3 seconds to reset the Check Filter Indicator.



Check Filter Indicator

- Lights up when the filter should be checked (see **Check Filter Indicator**, page 14).
- Reset the Check Filter Indicator light by pressing and holding the Sleep Mode button for 3 seconds.



Timer Button

- Cycles through timer options (see page 10).

GETTING STARTED

1. Flip the air purifier over. Twist the filter cover anticlockwise and remove it. *[Figure 1.1]*
2. Remove the filter from its plastic packaging and place the filter back into the air purifier. *[Figure 1.2]*
3. Replace the filter cover and twist clockwise to lock. *[Figure 1.3]*
4. Place the air purifier on a flat, stable surface with the display facing up. Allow at least 38 cm / 15 inches of clearance on all sides of the air purifier. Keep away from anything that would block airflow, such as curtains. *[Figure 1.4]*

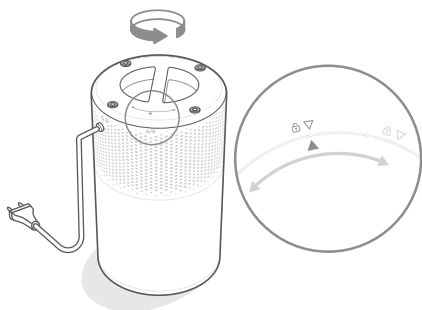

Figure 1.1

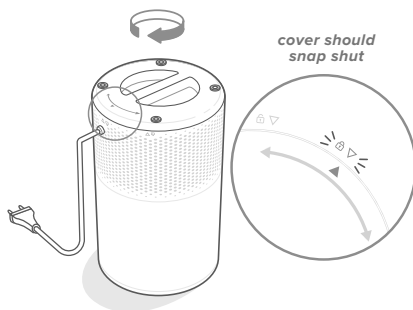

Figure 1.3

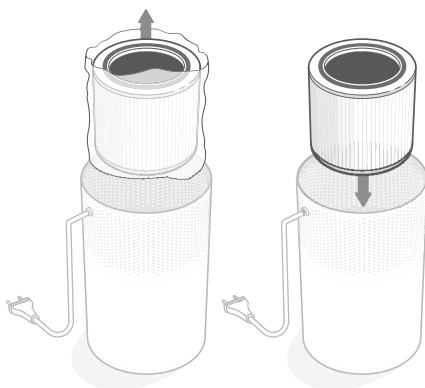

Figure 1.2

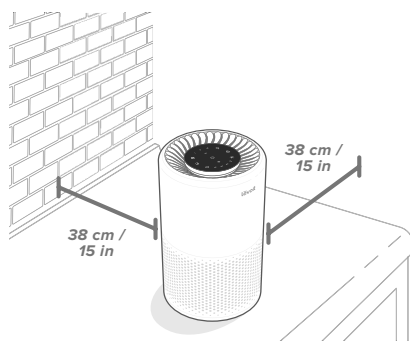

Figure 1.4

VESYNC APP SETUP

1. To download the VeSync app, scan the QR code or search “VeSync” in the Apple App Store® or Google Play Store.
2. Open the VeSync app. Log In or Sign Up.
3. Follow the in-app instructions to set up your smart air purifier.



CONNECT WITH AMAZON ALEXA OR GOOGLE ASSISTANT™



You can use the VeSync app to connect your smart air purifier to **Amazon Alexa** or **Google Assistant™**. Please follow the in-app instructions to set up your voice assistant.

Note: You must create your own VeSync account to access voice assistants.

USING YOUR SMART AIR PURIFIER

Note: Using the VeSync app allows you to control your air purifier remotely and access additional functions and features.

General Operation

1. Plug in and tap  to turn on the air purifier. The fan will start on level I. [Figure 2.1]
2. Optionally, tap  to change fan speed between I, II, and III.

Note:

- The indicators are not buttons and cannot be used to change the fan speed.
- The fan speed indicators will light up when active.
- Fan speed III is the loudest, but cleans air the quickest.
- For best results, or to address a specific air quality issue such as smoke, run the air purifier at high speed (level III) for 15–20 minutes before using a lower speed.
- To effectively clean air, keep windows and doors closed while the air purifier is on.

3. Tap  to turn off the air purifier.

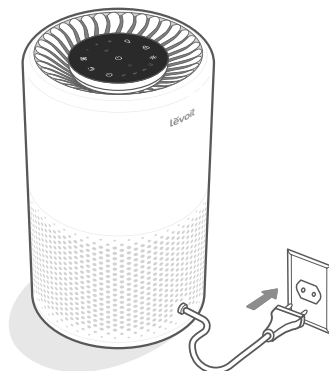

Figure 2.1

USING YOUR SMART AIR PURIFIER (CONT.)

Sleep Mode

Sleep Mode dims all icons to half brightness and operates quietly by using a fan speed lower than fan speed I.

Tap  to turn Sleep Mode on.

Note:



- Tapping  will exit Sleep Mode.
- You can still adjust the night light while the air purifier is in Sleep Mode.

Timer

You can manually set a timer for 2, 4, or 8 hours using the display buttons. You can also set a timer for 1 to 24 hours through the VeSync app.

1. Tap  repeatedly to select a time. The timer will start automatically.

Note:

- The indicators are not buttons and cannot be used to select a time.
 - The timer indicators will light up blue when active.
 -  indicator lights up when a timer is set up through the app.
2. Once the timer has finished, the air purifier will turn off.
 3. To cancel a timer, tap  until all timer indicators are off.

Note:

- You can change the fan speed at any time while the timer is on.
- The timer will restart if the time is changed.

Night Light



You can choose between 2 night light brightness levels, even when the air purifier is turned off (as long as it is still plugged in).

1. Tap once to turn on the light.
2. Tap a second time to dim the brightness to half.
3. Tap a third time to turn off the light.

Note: Turning off the display will not turn off the night light.

Display Lock

Locking the display prevents settings from being accidentally changed. Buttons will not respond to being tapped.

1. Press and hold  for 3 seconds to lock/unlock the display.
2. While the display is locked,  will light up. If other buttons are tapped,  will blink 3 times.

Memory Function

Even while turned off, as long as the air purifier is plugged in, it will remember its previous fan speed, Sleep Mode, and Display Lock settings.

When unplugged, the air purifier will remember the fan speed and Sleep Mode, but not Display Lock or Display Off.

Note: The memory function does not work with timers or night light settings.

VESYNC APP FUNCTIONS

The VeSync app allows you to access additional smart air purifier functions, including those listed below. As the app develops, more features may become available.

Remote Control

- Change any air purifier settings through the app, even while the Display Lock is on.

Schedules

- Create and customise schedules for your air purifier to match your routines.

Timer Function

- Set a timer setting between 1 and 24 hours.

Filter Replacement Info

- Keep tabs on remaining filter life by checking the filter life percentage in the app.
- Shop for replacement filters.

ABOUT THE FILTER

The air purifier uses a 3-stage filtration system to purify air.

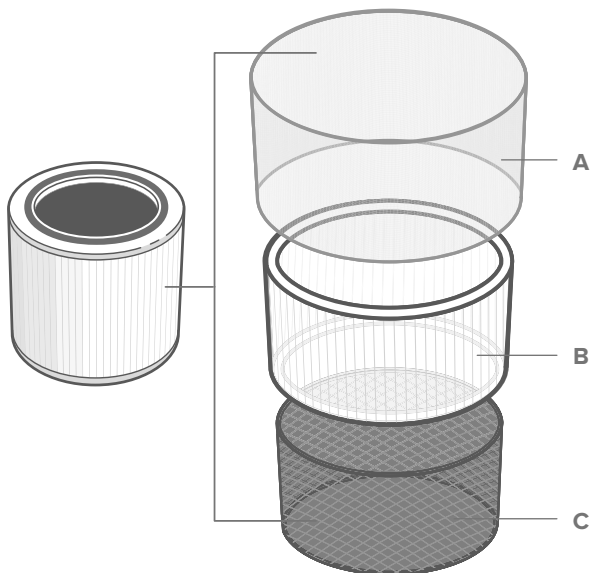

A. Nylon Pre-Filter

- Captures large particles such as dust, lint, fibres, hair, and pet fur.
- Maximises the True HEPA Filter's life by protecting it.

B. H13 True HEPA Filter

- Captures at least 99.97% of airborne particles 0.3 microns (μm) in size.
- Traps small particles such as mould spores, fine dust, smoke particles, bacteria and viruses*, and allergens such as pollen, dust mites, and pet dander.

C. High-Efficiency Activated Carbon Filter

- Physically adsorbs smoke, odours, and fumes.
- Filters compounds such as formaldehyde, benzene, ammonia, hydrogen sulphide and volatile organic compounds (VOCs).

*The H13 True HEPA Filter can remove most viruses and bacteria from the air, but cannot fully remove them from your environment. Air purifiers cannot prevent an infected person from spreading an infection, and cannot remove bacteria and viruses from surfaces. Please use this air purifier together with other precautions.

ABOUT THE FILTER (CONT.)

Clean Air Delivery Rate

This air purifier has a Clean Air Delivery Rate of 110 cubic feet per minute (CFM), or 170 m³/h.

Clean Air Delivery Rate (CADR) measures the efficiency of an air purifier by indicating the volume of clean air that it produces per minute. This is based on removal of dust, pollen, and smoke, which are the 3 most common indoor air pollutants. The higher the CADR, the more particles the air purifier will remove and the larger the area it can clean. The rating is measured at the air purifier's highest speed.

Air Change per Hour

The air change rate is how many times all of the air in a room can be purified (or "changed") by the air purifier in 1 hour. Air changes per hour are calculated on the recommended room size, assuming 2.4 m / 8 ft ceilings. For smaller rooms, the air change per hour will increase. This air purifier has an air change per hour of 2, which means it can change air 2 times per hour at the max speed in a single, closed room up to 35 m² / 376 ft². The air purifier is effective for larger rooms, but air purification will take longer, with fewer air changes per hour.

Note: *To effectively clean air, keep windows and doors closed while the air purifier is on.*

Humidity

Moisture may damage the filters. This air purifier should be used in an area with a humidity level below 85% RH. If you use the air purifier in excessively humid areas, the surface of the filter will become mouldy.

Note: *Water or moisture will allow mould to grow. To solve a mould problem, get rid of the source of the moisture and clean up the mould. Air purifiers cannot solve an existing mould problem, only capture airborne mould spores and reduce odours.*

Essential Oils



Do not add essential oils to the air purifier or filter. The filter will become damaged by the oil and will eventually release an unpleasant smell. **Do not** use diffusers near the air purifier.

CARE & MAINTENANCE

Cleaning the Smart Air Purifier

- Unplug before cleaning.
- Wipe the outside of the air purifier with a soft, dry cloth. If necessary, wipe the housing with a damp cloth, then immediately dry.
- Vacuum the inside of the air purifier.
- **Do not** clean with abrasive chemicals or flammable cleaning agents.

Check Filter Indicator

 will light up as a reminder to check the filter. Depending on how often you use the air purifier, the indicator should turn on within 6–8 months. You may not need to replace your filter yet, but you should check it when  turns on.

Note: When your air purifier is set up with the VeSync app, you can also check the app to see your remaining filter life. You will also receive a notification from VeSync when it's time to check your filter.







Cleaning the Filter

The outer pre-filter should be cleaned every 2–4 weeks to increase efficiency and extend the life of your filter. Clean the pre-filter using a soft brush or vacuum hose to remove hair, dust, and large particles.

Do not clean the filter with water or other liquids. [Figure 3.1]

Resetting the Check Filter Indicator

Reset the Check Filter Indicator when:

- A.  lights up red.
1. Replace the filter (see page 15).
 2. Turn on the air purifier.
 3. Press and hold  for 3 seconds.  will blink 3 times and turn off once successfully reset.
- B. The filter was changed before  lit up.
3. Press and hold  for 3 seconds.  will blink 3 times and turn off once successfully reset.

Note: You can also reset the Check Filter Indicator in the VeSync app.

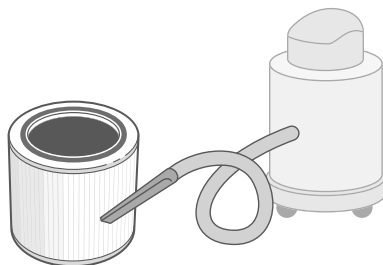



Figure 3.1

Filter	When to Clean	How to Clean	When to Replace
Nylon Pre-Filter	Every 2–4 weeks	Use a soft brush or vacuum hose [Figure 3.1]	6–8 months
True HEPA & High-Efficiency Activated Carbon Filters	Do not clean		

CARE & MAINTENANCE (CONT.)

When Should I Replace the Filter?

Check the VeSync app to see your remaining filter life.

The filter should be replaced every 6–8 months. You may need to replace your filter sooner or later depending on how often you use your air purifier. Using your air purifier in an environment with relatively high pollution may mean you will need to replace the filter more often, even if  is off.

You may need to replace your filter if you notice:

- Increased noise when the air purifier is on
- Decreased airflow
- Unusual odours
- A visibly clogged filter

Note:

- To maintain the performance of your air purifier, **only** use official Levoit filters. To buy replacement filters, go to Amazon and search **B08H25J3J1**.



- Remember to reset  after changing the filter (see page 14).

Replacing the Filter

1. Unplug the air purifier. Flip the air purifier over and remove the filter cover (see **Getting Started**, page 8).
2. Remove the old filter.
3. Clean out any remaining dust or hair inside the air purifier using a vacuum hose. **Do not** use water or liquids to clean the air purifier. [Figure 3.2]
4. Unwrap the new filter and place it into the housing (see **Getting Started**, page 8).
5. Replace the cover. Plug in the air purifier.
6. Reset the Check Filter Indicator (see page 14).

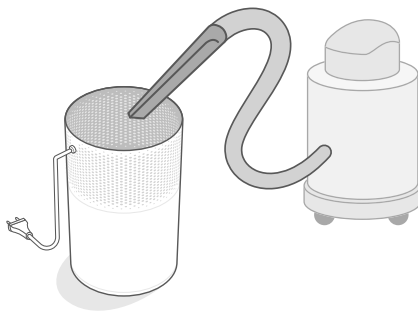



Figure 3.2









Storage

If not using the air purifier for an extended period of time, wrap both the air purifier and the filter in plastic packaging and store in a dry place to avoid moisture damage.

TROUBLESHOOTING

Problem	Possible Solution
Air purifier will not turn on or respond to button controls.	Plug in the air purifier.
	Check to see if the power cord is damaged. If so, stop using the air purifier and contact Customer Support (see page 20).
	Plug the air purifier into a different outlet.
	The air purifier may be malfunctioning. Contact Customer Support (see page 20).
Airflow is significantly reduced.	Make sure the filter is removed from its packaging and properly in place (see page 8).
	Tap  to increase the fan speed.
	Make sure there are at least 38 cm / 15 inches of clearance on all sides of the air purifier.
	The pre-filter may be clogged by large particles, such as hair or lint, blocking air flow. Clean the pre-filter (see page 14).
Air purifier makes an unusual noise while the fan is on.	Replace the filter (see page 15).
	Make sure the filter is properly in place with plastic packaging removed (see page 8).
	Make sure the air purifier is operating on a hard, flat, level surface.
	Replace the filter (see page 15).
Strange smell coming from the purifier.	The air purifier may be damaged, or a foreign object may be inside. Stop using the air purifier and contact Customer Support (see page 20). Do not try to repair the air purifier.
	Clean the filter or replace if necessary.
Strange smell coming from the purifier.	Make sure not to use your air purifier in an area with high humidity or while diffusing essential oils.

TROUBLESHOOTING (CONT.)

Problem	Possible Solution
Poor air purification quality.	Tap  to increase the fan speed.
	Make sure no objects are blocking the sides or top of the air purifier (the inlet or outlet).
	Make sure the filter is removed from its packaging and properly in place (see page 8).
	Close doors and windows while using the air purifier.
	If the room is larger than 35 m ² / 376 ft ² , air purification will take longer. The air purifier may not be as effective in significantly larger rooms.
	Replace the filter (see page 15).
 is still on after replacing the filter.	Reset the Check Filter Indicator (see page 14).
 has not turned on within 8 months.	 is a reminder for you to check the filter and will light up based on how long the air purifier has been used (see page 14). If you don't use your air purifier often,  will take longer to turn on.
 turned on before 6 months.	 is a reminder for you to check the filter and will light up based on how long the air purifier has been used (see page 14). If you run your air purifier frequently,  will turn on sooner.

If your problem is not listed, please contact **Customer Support** (see page 20).

VESYNC APP TROUBLESHOOTING

My smart air purifier isn't connecting to the VeSync app.

- Make sure your phone has Bluetooth® turned on and is not currently connected to another Bluetooth device.
- During the setup process, you must be on a secure 2.4GHz Wi-Fi network. Confirm that the network is working correctly.
- Make sure the Wi-Fi password you entered is correct.
 - There should be no spaces at the beginning or end of the password.
 - Test the password by connecting a different electronic device to the router.
 - If you're manually typing in the SSID and password, double check that both are entered correctly.
- Try moving your air purifier closer to the router. Your phone should be as close as possible to your air purifier.
- Your router may need to be at a higher location, away from obstructions.
- Make sure your air purifier and router are away from appliances (such as microwave ovens, refrigerators, electronic devices, etc.) to avoid signal interference.
- If you're using a VPN, make sure it's turned off while setting up your air purifier.
- Disable portal authentication for your Wi-Fi network. If portal authentication is enabled, the air purifier will not be able to access your Wi-Fi network, and setup will fail.

***Note:** Portal authentication means that you need to sign in to your Wi-Fi network through a web page before you can use the Internet.*

My air purifier is offline.

- Make sure the air purifier is plugged in and has power, then refresh the VeSync menu by swiping down on the screen.
- Make sure your router is connected to the internet and your phone's network connection is working.
- Delete the offline air purifier from the VeSync app. Swipe left (iOS®) or press and hold (Android™), then tap **Delete**.
- Reconfigure the air purifier with the VeSync app.

***Note:** Power outages, internet outages, or changing Wi-Fi routers may cause the air purifier to go offline.*

If your problem is not listed, please contact **Customer Support** (see page 20).

ABOUT ENERGY-RELATED PRODUCTS

The product, in accordance with the Eco-design Requirements for Energy Related Products Directive 2009/125/EC, is in compliance with the following norm(s) or document(s): Regulation (EC) NO. 1275/2008, as amended by Regulation (EU) No. 801/2013.

Required Power State Information	Networked Standby
Power consumption in specified power mode, at 230V/50Hz input	≤ 2.0W
Time after which equipment is automatically switched into mode	Immediately
Network port deactivation/activation procedures	Disconnecting the Wi-Fi connection will deactivate the Wi-Fi network. Connecting the device to Wi-Fi will activate the Wi-Fi network.
Networked Standby Mode: When the Wi-Fi network is activated, press and hold the on/off button, and the device will immediately enter the networking standby state.	

WARRANTY INFORMATION

Product Name	Smart True HEPA Air Purifier
Model	Core 200S
<i>For your own reference, we strongly recommend that you record your order ID and date of purchase.</i>	
Date of Purchase	
Order ID	

Terms & Policy

Arovast Corporation warrants all products to be of the highest quality in material, craftsmanship, and service for 2 years, effective from the date of purchase to the end of the warranty period. Warranty lengths may vary between product categories.

If you have any questions or concerns about your new product, please contact our helpful Customer Support Team.

CUSTOMER SUPPORT

Arovast Corporation

1202 N. Miller St., Suite A
Anaheim, CA 92806
USA

Email: support.eu@levoit.com

*Please have your order invoice and order ID ready before contacting Customer Support.

Trademark Information

Amazon, Alexa, and all related logos are trademarks of Amazon.com, Inc. or its affiliates.

Google, Android, and Google Play are trademarks of Google LLC.

Apple App Store is a trademark of Apple Inc.

Wi-Fi® is a registered trademark of Wi-Fi Alliance®.

The Bluetooth® word mark and logos are registered trademarks owned by Bluetooth SIG, Inc. and any use of such marks by Arovast Corporation is under license. Other trademarks and trade names are those of their respective owners.

iOS is a registered trademark of Cisco Systems, Inc. and/or its affiliates in the United States and certain other countries.

lėvoit®

LEVOIT.COM

Connect With Us

Verbinden Sie
sich mit uns

Restez connecté

Conecte con
nosotros en

Seguici su



/LEVOITUK



/LEVOITUK
/LEVOITGERMANY
/LEVOITFRANCE
/LEVOITSPAIN
/LEVOITITALY