

AG1000

GB OWNER'S OPERATING MANUAL

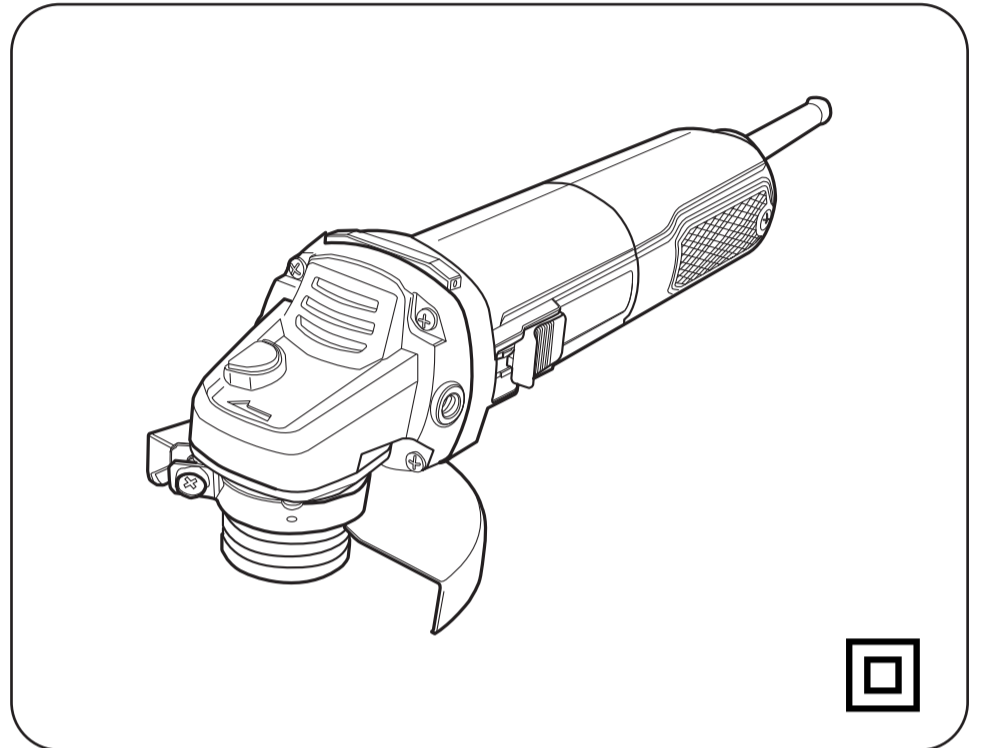

KYOCERA Industrial Tools Corporation
2-2-54 Matsuhama-cho, Fukuyama-shi,
Hiroshima-ken, 720-0802 Japan

69800632-00 STD
12-20

GB ENGLISH

SANDING OPERATIONS

Selecting Sanding Disc

Sanding discs are made of extremely hard and sharp aluminum oxide grits, phenol-resin bonded to a sturdy fiber backing for fast heavy-duty service and long life. The discs vary as to size and spacing of the abrasive grits. OPEN COAT (type H) — used for soft materials and on paint or varnish. CLOSED COAT (type K) — used for metal, hardwood, stone, marble and other materials.

Sanding discs range in grit from 16 (very coarse) to 180 (very fine). To obtain best results, select sanding discs carefully. Many jobs require the use of several grit sizes and at times both "open coat and closed coat" discs are required to get the job done faster. See chart for application examples.

Operation: Refinishing painted wood or metal surfaces.	
REMARKS	GRIT
To remove paint and to smooth surface irregularities.	Coarse 16-24-30
To smooth the rough sanding	Medium 36-50-80
To remove scratches left by previous discs	Fine 100-120
To smooth surfaces for painting, polishing or waxing	Very fine 150-180

SANDING TIPS

For best results, tilt the Disc Sander at a 10° to 15° angle while sanding so that only about 1" of the surface around the edge of the disc contacts the work.

WARNING!

If the disc (accessory) is held flat or the back edge of the disc comes in contact with the work, a violent thrust to the side may result.

If sander is tilted too much, sanding action will be too great and a rough cut surface or gouging and snagging will result. Guide the Disc Sander with crosswise strokes. Be careful not to hold the sander in one spot too long. Do not use a circular motion, as this makes swirl marks. Test before use on scrap stock.

Do not force or apply pressure when sanding. Use only the weight of the tool for pressure. Excess pressure actually slows the tool down. If faster stock removal is desired, change to a coarser grit disc.

Remove gummy paint from metal with an "open coat" disc. Sand until sparks start to appear, then stop and change to a "closed coat" disc to remove any remaining paint.

SANDING WOOD

When sanding wood the direction of the disc motion at the contact point should parallel the grain as much as possible. The rapid cut of discs and the swirl type scratch pattern they occasionally create generally prohibit their use for producing the final finish. Scratches and circular marks are usually the result of using too coarse a grit. When changing to a finer grit, move across the sanding lines that were made by a previous coarser disc.

SANDING METAL

When sanding automobiles or appliances, wipe the metal clean with a non-flammable solvent or commercial cleaner to remove all wax and grease. By doing this first, the sanding discs will sand better and last longer.

For heavy duty work, use a coarse grit disc first. Follow-up with a medium grit to remove scratches. To produce smooth finish, use fine grit disc.

MAINTENANCE

After use, check the tool to make sure that it is in top condition. It is recommended that you take this tool to an Authorized Service Center for a thorough cleaning and lubrication at least once per year.

DO NOT MAKE ANY ADJUSTMENTS WHILE THE MOTOR IS IN MOTION.

ALWAYS DISCONNECT THE POWER CORD FROM THE RECEPTACLE BEFORE CHANGING REMOVABLE OR EXPENDABLE PARTS (BLADE, BIT, SANDING PAPER ETC.), LUBRICATING OR WORKING ON THE UNIT.

WARNING!

To ensure safety and reliability, all repairs should be performed by an AUTHORIZED SERVICE CENTER or other QUALIFIED SERVICE ORGANIZATION.

SAVE THESE INSTRUCTIONS FOR FUTURE REFERENCE.

□ Class II construction tool in which protection against electric shock does not rely on basic insulation only, but in which additional safety precaution, such as double insulation or reinforced insulation, are provided "

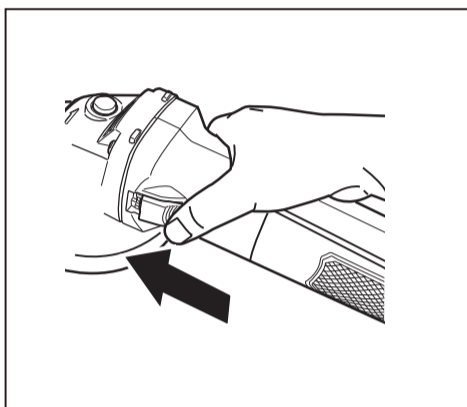
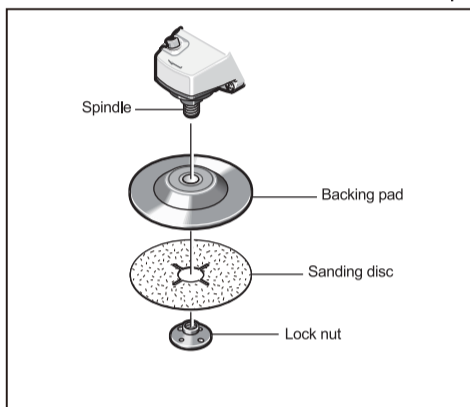
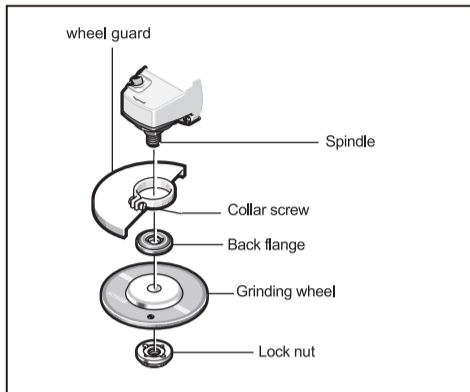
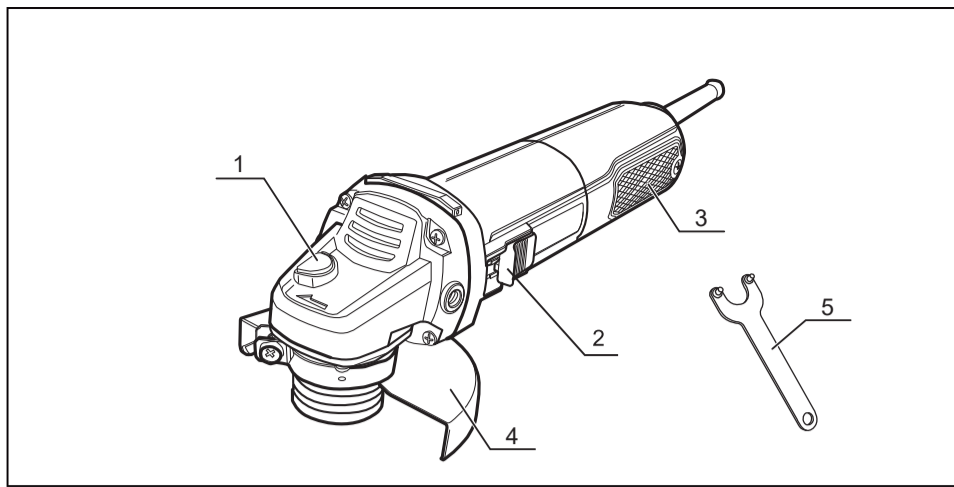

1

2

3

THANK YOU FOR BUYING OUR PRODUCT.

To ensure your safety and satisfaction, carefully read through this OWNER'S MANUAL before using the product.

General Power Tool Safety Warnings

⚠ WARNING! Read all safety warnings, instructions, illustrations and specifications provided with this power tool. Failure to follow all instructions listed below may result in electric shock, fire and/or serious injury.

Save all warnings and instructions for future reference.

The term "power tool" in the warnings refers to your corded or battery-operated (cordless) power tool.

- 1) **Work area safety**
 - a) **Keep work area clean and well lit.** Cluttered or dark areas invite accidents.
 - b) **Do not operate power tools in explosive atmospheres, such as in the presence of flammable liquids, gases or dust.** Power tools create sparks which may ignite the dust or fumes.
 - c) **Keep children and bystanders away while operating a power tool.** Distractions can cause you to lose control.
- 2) **Electrical safety**
 - a) **Power tool plugs must match the outlet. Never modify the plug in any way. Do not use any adapter plugs with grounded power tools.** Unmodified plugs and matching outlets will reduce risk of electric shock.
 - b) **Avoid body contact with grounded surfaces such as pipes, radiators, ranges and refrigerators.** There is an increased risk of electric shock if your body is grounded.
 - c) **Do not expose power tools to rain or wet conditions.** Water entering a power tool will increase the risk of electric shock.
 - d) **Do not abuse the cord. Never use the cord for carrying, pulling or unplugging the power tool. Keep cord away from heat, oil, sharp edges or moving parts.** Damaged or entangled cords increase the risk of electric shock.
 - e) **When operating a power tool outdoors, use an extension cord suitable for outdoor use.** Use of a cord suitable for outdoor use reduces the risk of electric shock.
 - f) **If operating a power tool in a damp location is unavoidable, use a ground fault circuit interrupter (GFCI) protected supply.** Use of an GFCI reduces the risk of electric shock.
- 3) **Personal safety**
 - a) **Stay alert, watch what you are doing and use common sense when operating a power tool. Do not use a power tool while you are tired or under the influence of drugs, alcohol or medication.** A moment of inattention while operating power tools may result in serious personal injury.
 - b) **Use personal protective equipment. Always wear eye protection.** Protective equipment such as dust mask, non-skid safety shoes, hard hat, or hearing protection used for appropriate conditions will reduce personal injuries.
 - c) **Prevent unintentional starting. Ensure the switch is in the off-position before connecting to power source and/or battery pack, picking up or carrying the tool. Carrying power tools with your finger on the switch or energising power tools that have the switch on invites accidents.**
 - d) **Remove any adjusting key or wrench before turning the power tool on.** A wrench or a key left attached to a rotating part of the power tool may result in personal injury.
 - e) **Do not overreach. Keep proper footing and balance at all times.** This enables better control of the power tool in unexpected situations.
 - f) **Dress properly. Do not wear loose clothing or jewelry. Keep your hair, clothing and gloves away from moving parts.** Loose clothes, jewelry or long hair can be caught in moving parts.

- g) **If devices are provided for the connection of dust extraction and collection facilities, ensure these are connected and properly used.** Use of dust collection can reduce dust-related hazards.
 - h) **Do not let familiarity gained from frequent use of tools allow you to become complacent and ignore tool safety principles.** A careless action can cause severe injury within a fraction of a second.
- 4) **Power tool use and care**
- a) **Do not force the power tool. Use the correct power tool for your application.** The correct power tool will do the job better and safer at the rate for which it was designed.
 - b) **Do not use the power tool if the switch does not turn it on and off.** Any power tool that cannot be controlled with the switch is dangerous and must be repaired.
 - c) **Disconnect the plug from the power source and/or the battery pack from the power tool before making any adjustments, changing accessories, or storing power tools.** Such preventive safety measures reduce the risk of starting the power tool accidentally.
 - d) **Store idle power tools out of the reach of children and do not allow persons unfamiliar with the power tool or these instructions to operate the power tool.** Power tools are dangerous in the hands of untrained users.
 - e) **Maintain power tools. Check for misalignment or binding of moving parts, breakage of parts and any other condition that may affect the power tools operation. If damaged, have the power tool repaired before use.** Many accidents are caused by poorly maintained power tools.
 - f) **Keep cutting tools sharp and clean.** Properly maintained cutting tools with sharp cutting edges are less likely to bind and are easier to control.
 - g) **Use the power tool, accessories and tool bits etc. in accordance with these instructions, taking into account the working conditions and the work to be performed.** Use of the power tool for operations different from those intended could result in a hazardous situation.
 - h) **Keep handles and grasping surfaces dry, clean and free from oil and grease.** Slippery handles and grasping surfaces do not allow for safe handling and control of the tool in unexpected situations.
- 5) **Service**
- a) **Have your power tool serviced by a qualified repair person using only identical replacement parts.** This will ensure that the safety of the power tool is maintained.

Safety Warnings Common for Grinding, Sanding or Polishing Operations:

- a) **This power tool is intended to function as a grinder, sander or polisher tool. Read all safety warnings, instructions, illustrations and specifications provided with this power tool.** Failure to follow all instructions listed below may result in electric shock, fire and/or serious injury.
- b) **Operation such as wire brushing or cutting-off are not recommended to be performed with this power tool.** Operations for which the power tool was not designed may create a hazard and cause personal injury.
- c) **Do not use accessories which are not specifically designed and recommended by the tool manufacturer.** Just because the accessory can be attached to your power tool, it does not assure safe operation.
- d) **The rated speed of the accessory must be at least equal to the maximum speed marked on the power tool.** Accessories running faster than their rated speed can break and fly apart.
- e) **The outside diameter and the thickness of your accessory must be within the capacity rating of your power tool.** Incorrectly sized accessories cannot be adequately guarded or controlled.

- f) **Threaded mounting of accessories must match the grinder spindle thread. For accessories mounted by flanges, the arbour hole of the accessory must fit the locating diameter of the flange.** Accessories that do not match the mounting hardware of the power tool will run out of balance, vibrate excessively and may cause loss of control.
- g) **Do not use a damaged accessory. Before each use inspect the accessory such as abrasive wheels for chips and cracks, backing pad for cracks, tear or excess wear, wire brush for loose or cracked wires. If power tool or accessory is dropped, inspect for damage or install an undamaged accessory. After inspecting and installing an accessory, position yourself and bystanders away from the plane of the rotating accessory and run the power tool at maximum no-load speed for one minute.** Damaged accessories will normally break apart during this test time.
- h) **Wear personal protective equipment. Depending on application, use face shield, safety goggles or safety glasses. As appropriate, wear dust mask, hearing protectors, gloves and workshop apron capable of stopping small abrasive or workpiece fragments.** The eye protection must be capable of stopping flying debris generated by various operations. The dust mask or respirator must be capable of filtering particles generated by your operation. Prolonged exposure to high intensity noise may cause hearing loss.
- i) **Keep bystanders a safe distance away from work area. Anyone entering the work area must wear personal protective equipment.** Fragments of workpiece or of a broken accessory may fly away and cause injury beyond immediate area of operation.
- j) **Hold the power tool by insulated gripping surfaces only, when performing an operation where the cutting accessory may contact hidden wiring or its own cord.** Cutting accessory contacting a "live" wire may make exposed metal parts of the power tool "live" and shock the operator.
- k) **Position the cord clear of the spinning accessory.** If you lose control, the cord may be cut or snagged and your hand or arm may be pulled into the spinning accessory.
- l) **Never lay the power tool down until the accessory has come to a complete stop.** The spinning accessory may grab the surface and pull the power tool out of your control.
- m) **Do not run the power tool while carrying it at your side.** Accidental contact with the spinning accessory could snag your clothing, pulling the accessory into your body.
- n) **Regularly clean the power tool's air vents.** The motor's fan will draw the dust inside the housing and excessive accumulation of powdered metal may cause electrical hazards.
- o) **Do not operate the power tool near flammable materials.** Sparks could ignite these materials.
- p) **Do not use accessories that require liquid coolants.** Using water or other liquid coolants may result in electrocution or shock.

Kickback and Related Warnings

Kickback is a sudden reaction to a pinched or snagged rotating wheel, backing pad, brush or any other accessory. Pinching or snagging causes rapid stalling of the rotating accessory which in turn causes the uncontrolled power tool to be forced in the direction opposite of the accessory's rotation at the point of the binding.

For example, if an abrasive wheel is snagged or pinched by the workpiece, the edge of the wheel that is entering into the pinch point can dig into the surface of the material causing the wheel to climb out or kick out. The wheel may either jump toward or away from the operator, depending on direction of the wheel's movement at the point of pinching. Abrasive wheels may also break under these conditions.

Kickback is the result of power tool misuse and/or incorrect operating procedures or conditions and can be avoided by taking proper precautions as given below.

- a) **Maintain a firm grip on the power tool and position your body and arm to allow you to resist kickback forces.** The operator can control torque reactions or kickback forces, if proper precautions are taken.
- b) **Never place your hand near the rotating accessory.** Accessory may kickback over your hand.
- c) **Do not position your body in the area where power tool will move if kickback occurs.** Kickback will propel the tool in direction opposite to the wheel's movement at the point of snagging.
- d) **Use special care when working corners, sharp edges etc. Avoid bouncing and snagging the accessory.** Corners, sharp edges or bouncing have a tendency to snag the rotating accessory and cause loss of control or kickback.
- e) **Do not attach a saw chain woodcarving blade or toothed saw blade.** Such blades create frequent kickback and loss of control.

Safety Warnings Specific for Grinding Operations:

- a) **Use only wheel types that are recommended for your power tool and the specific guard designed for the selected wheel.** Wheels for which the power tool was not designed cannot be adequately guarded and are unsafe.
- b) **The grinding surface of centre depressed wheels must be mounted below the plane of the guard lip.** An improperly mounted wheel that projects through the plane of the guard lip cannot be adequately protected.
- c) **The guard must be securely attached to the power tool and positioned for maximum safety, so the least amount of wheel is exposed towards the operator.** The guard helps to protect the operator from broken wheel fragments, and sparks that could ignite clothing, accidental contact with wheel.
- d) **Wheels must be used only for recommended applications. For example: do not grind with the side of cut-off wheel.** Abrasive cut-off wheels are intended for peripheral grinding, side forces applied to these wheels may cause them to shatter.
- e) **Always use undamaged wheel flanges that are of correct size and shape for your selected wheel.** Proper wheel flanges support the wheel thus reducing the possibility of wheel breakage.
- f) **Do not use worn down wheels from larger power tools.** Wheel intended for larger power tool is not suitable for the higher speed of a smaller tool and may burst.

Safety Warnings Specific for Sanding Operations:

- a) **Do not use excessively oversized sanding disc paper. Follow manufacturers recommendations, when selecting sanding paper.** Larger sanding paper extending beyond the sanding pad presents a laceration hazard and may cause snagging, tearing of the disc or kickback.

Safety Warnings Specific for Polishing Operations:

- a) **Do not allow any loose portion of the polishing bonnet or its attachment strings to spin freely. Tuck away or trim any loose attachment strings.** Loose and spinning attachment strings can entangle your fingers or snag on the workpiece.

INSTRUCTIONS FOR SAFE HANDLING

1. Make sure that the tool is only connected to the voltage marked on the rating plate.
2. Never use the tool if its cover or any bolts are missing. If the cover or bolts have been removed, replace them prior to use. Maintain all parts in good working order.
3. Never touch the blade, drill bit, grinding wheel or other moving parts during use.
4. Never start a tool when its rotating component is in contact with the work piece.

5. Grinding wheels must be stored in a dry place. Do not put any object on the wheels. Grinding wheels must not be used for any operation other than grinding. Grinding wheels must be stored and handled with care in accordance with the manufacturer's instruction.
6. Ensure that the wheel is fitted in accordance with this manual.
7. Ensure that the grinding wheel is correctly mounted and tightened before use and run the tool at no-load speed for 30 seconds in a safe position. Stop immediately if there is considerable vibration or if other defects are detected. If this condition occurs, check the tool to determine the cause.
8. Check that the work piece is properly supported.
9. Do not remove the soft paper in the center of the grinding wheel. (If the paper has been previously removed, insert some soft paper or rubber between grinding wheel and flange.)
10. Grip the tool securely with both hands while operating.

DESCRIPTION

1. Spindle lock
2. Switch button
3. Dustproof filter
4. Wheel guard
5. Wrench

SPECIFICATIONS

Capacities	
Grinding wheel	100 mm x 6mm
Sanding disc	100 mm
Input	900 W
Spindle thread	M10
Rated speed	13,000 min ⁻¹
Dimensions	272 mm x 115 mm x 97 mm
Net weight	1.6 kg

* Be sure to check the nameplate on the product, because the voltage is subject to change depending on the area in which the product is to be used.

Do not use wheels having a Maximum permissible circumferential speed below 4,800 m/min.

STANDARD ACCESSORIES

Wrench

APPLICATIONS

(Use only for the purposes listed below.)

1. Grinding and finishing for welds.
2. Deburring and finishing iron, bronze, aluminum, and other metal castings.
3. Surface finishing with sanding disc.

ASSEMBLY

WHEEL GUARD INSTALLATION

WARNING!

Wheel guard must be attached when using disc grinding wheels. Always keep wheel guard between you and your work while grinding.

To attach the wheel guard DISCONNECT tool from power source. Position the guard on spindle neck, then secure guard with the collar screw.

LOCK NUT AND BACKING FLANGE

Your tool is equipped with a threaded spindle for mounting accessories. Always use the supplied lock nut (and backing flange) that has same thread size as spindle.

DISC GRINDING WHEEL ASSEMBLY (Fig.1)

Disconnect tool from power source. Be sure that wheel guard is in place for grinding. Thread BACKING FLANGE onto spindle, then place GRINDING WHEEL on the spindle. Thread on the lock nut and tighten nut using the supplied wrench, while holding the spindle lock in. TO REMOVE: Reverse procedure.

INSTALLATION OF SANDING DISC AND POLISHING OPERATIONS (Fig.2)

For installation of aftermarket sanding disc and polishing pad, read instruction in each operation manual.

OPERATION

SLIDE ON-OFF SWITCH WITH LOCK (Fig. 3)

The tool is switched "ON" by the switch button located at the top of the motor housing. The switch can be locked in the "ON" position, a convenience for long grinding operations. To turn the tool "ON" without locking it, slide the switch button forward by applying pressure ONLY at the REAR portion of the button. When pressure is released the switch button will snap to "OFF" position.

To lock the switch "ON", slide the switch button forward and press "IN" the FRONT portion.

To unlock the switch, simply press and release the REAR portion of the button. Switch is spring loaded and will snap back automatically.

WARNING!

Hold the tool with both hands while starting the tool, since torque from the motor can cause the tool to twist.

Start the tool before applying to work and let the tool come to full speed before contacting the workpiece. Lift the tool from the work before releasing the switch. DO NOT turn the switch "ON" and "OFF" while the tool is under load; this will greatly decrease the switch life.

GRINDING OPERATION

Selecting Grinding Wheels

WARNING!

Before using a grinding wheel, be certain that its maximum safe operating speed is not exceeded by the nameplate speed of the grinder. Do not exceed the recommended wheel diameter.

Disc Grinding Wheels

Grinding wheels should be carefully selected in order to use the grinder most efficiently. Wheels vary in type of abrasive, bond, hardness, grit size and structure. The correct type of wheel to use is determined by the job. Use disc grinding wheels for fast grinding of structural steel, heavy weld beads, steel casting, stainless steel and other ferrous metals.

Grinding Tips

Efficient grinding is achieved by controlling the pressure and keeping the angle between wheel and workpiece at 10° to 15°. If the wheel is flat, the tool is difficult to control. If the angle is too steep, the pressure is concentrated on a small area causing burning to the work surface.

WARNING!

Excessive or sudden pressure on the wheel will slow grinding action and put dangerous stresses on the wheel.

When grinding with a new wheel be certain to grind while pulling tool backwards until wheel becomes rounded on its edge. New wheels have sharp corners which tend to "bite" or cut into workpiece when pushing forward.